

Available In White Or Black Hardware As Standard

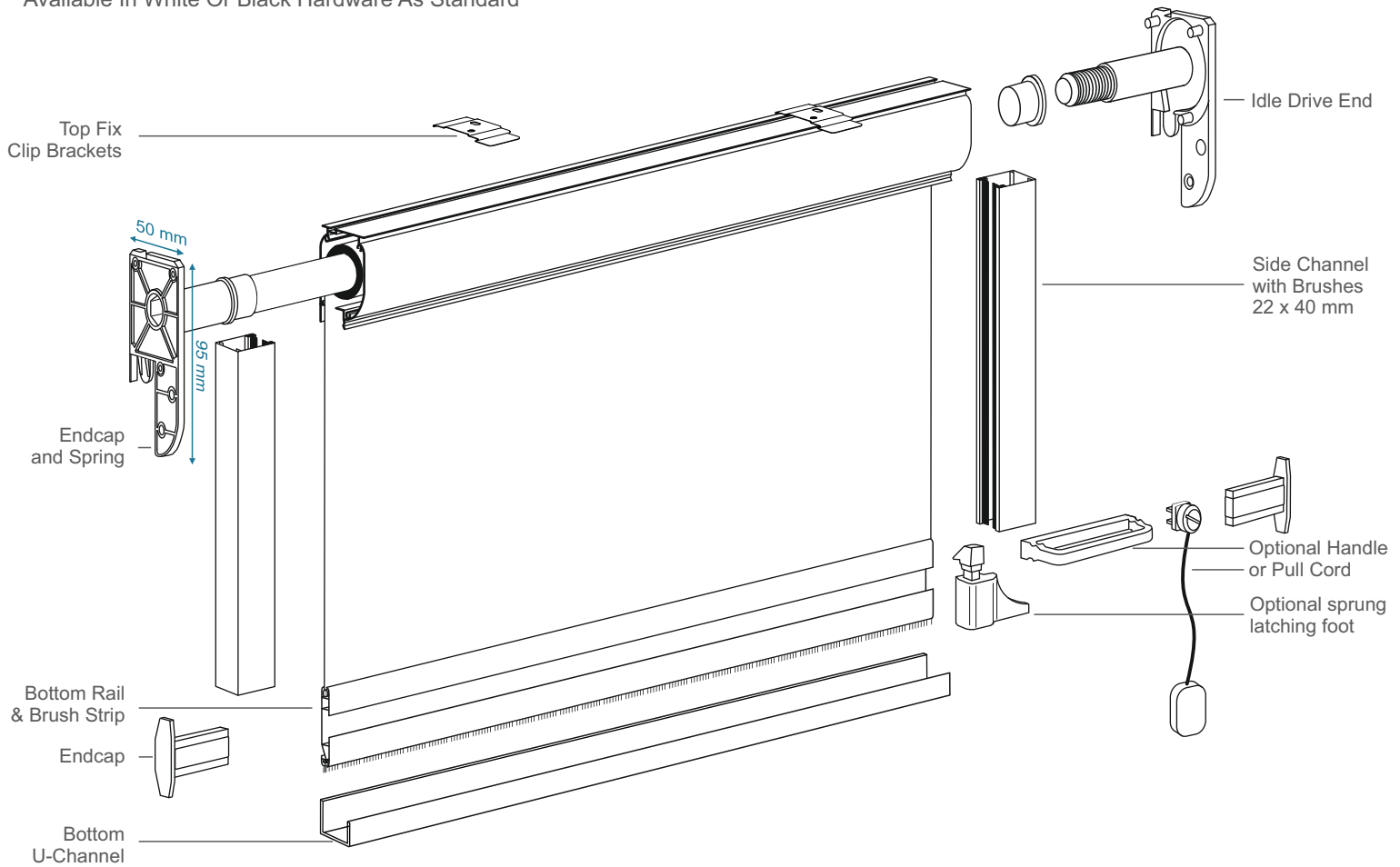

- Manufactured in the UK, with a long established design that has proven reliability and long lasting performance.
- A robust, fully integrated system using roller blind cassette and side channels with optional bottom channel to reduce light strike between the blind and recess.
- Suitable for blind sizes up to 2.2m wide and 2.00 m drop, dependant on fabric choice. Larger sizes can be accommodated using our other systems.
- Extrusions are aluminium, powder coated to either white or black finish as standard. Custom hardware to a RAL colour available at additional cost.
- Light exclusion is most effective with black hardware and fabric. A silicone sealant should be applied to channels and top box to prevent light bleed around edges.
- Recess top fixing uses spring clip brackets, side recess fixing is through box end caps and side channels.
- Spring operation with the option of either pull handle or cord pull. Cord pulls are limited to 200 mm in length for safety reasons, however a longer cord length can be specified and will be house in a cord should in accordance with blind cord safety regulations. Please contact us for further information on safety.

Contact Us

01732 469 418  
sales@electricblindcompany.com

Unit 7 North Downs Business Park  
Limepit Lane, Sevenoaks, TN13 2TL